

Vocal fader IC

BA3837 / BA3837F / BA3838F

The BA3837, BA3837F and BA3838F are ICs with an internal secondary active LPF for vocal cancellation functions and mixing amplifier functions with high degrees of vocal cancellation. Three control pins are used to switch between modes: the key controller input mode, through mode, vocal fader mode, sound multiplexing mode and mute mode. By offering these functions on a single chip, these ICs can significantly reduce the number of external components.

●Applications

Karaoke functions on stereo systems, portable stereos and VCRs

●Features

- 1) Single-chip IC with vocal fader, to erase vocals from commercially available recordings.
- 2) Internal secondary active LPF for high degrees of vocal cancellation (high synchronization rejection).
- 3) Three control pins for switching between 4 modes: through, vocal fader, sound multiplexing and mute.
- 4) Key controller input and internal switches.
- 5) Low noise and low distortion.
- 6) Internal microphone mixing amplifier.
- 7) Available in two packages: DIP 16-pin and SOP 16-pin (BA3838F is available in SOP 16-pin only).

●Absolute maximum ratings (Ta = 25°C)

| Parameter | | Symbol | Limits | Unit |
|-----------------------|-------|------------------|--------------|------|
| Power supply voltage | | V _{CC} | 18 | V |
| Power dissipation | DIP16 | P _d | 1000*1 | mW |
| | SOP16 | | 550*2 | |
| Operating temperature | | T _{opr} | - 40 ~ + 85 | °C |
| Storage temperature | | T _{stg} | - 55 ~ + 125 | °C |

*1 Reduced by 10 mW for each increase in Ta of 1°C over 25°C.

*2 Reduced by 5.5mW for each increase in Ta of 1°C over 25°C.

●Recommended operating conditions (Ta = 25°C)

| Parameter | Symbol | Min. | Typ. | Max. | Unit | Conditions |
|------------------------|-----------------|------|------|------|------|----------------------|
| Power supply voltage*1 | V _{CC} | 5.4 | — | 10 | V | Ta = - 40°C ~ + 85°C |
| Power supply voltage*1 | V _{CC} | 5.4 | — | 13 | V | Ta = - 40°C ~ + 60°C |
| Power supply voltage*2 | V _{CC} | 4.0 | — | 15 | V | Ta = 25°C |

*1 BA3837 and BA3837F

*2 BA3838F

●Block diagram

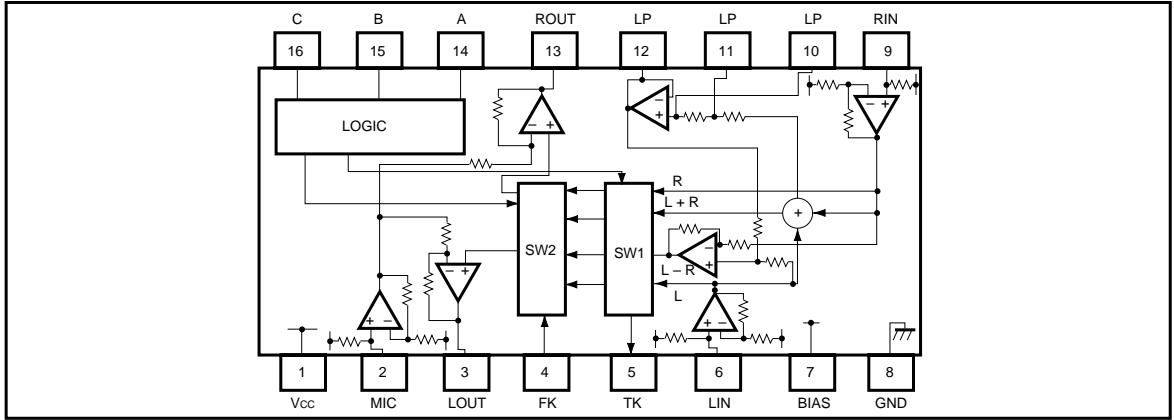

●Pin descriptions

| Pin No. | Pin name | Equivalent circuit | Function |
|---------|----------|--|---------------------------------------|
| 1 | Vcc | | |
| 2 | MIC IN | | Mixing input pin for microphone sound |
| 3 | LOUT | | Lch output pin |
| 4 | FK | | Input pin for key controller signals |
| 5 | TK | <p>BA3837 / BA3837F</p> <p>BA3838F</p> | Output pin for key controller signals |

| Pin No. | Pin name | Equivalent circuit | Function |
|---------|----------|--------------------|-------------------------|
| 6 | LIN | | L signal input pin |
| 7 | BIAS | | Signal bias circuit pin |
| 8 | GND | | |
| 9 | RIN | | R signal input pin |
| 10 | LPF1 | | LPF time constant pin |
| 11 | LPF2 | | LPF time constant pin |

| Pin No. | Pin name | Equivalent circuit | Function |
|---------|----------|--------------------|----------------------|
| 12 | LPF3 | | LPF output pin |
| 13 | ROUT | | R output pin |
| 14 | CONTA | | Mode switching pin A |
| 15 | CONTB | | Mode switching pin B |
| 16 | CONTC | | Mode switching pin C |

●Electrical characteristics

BA3837 / F (unless otherwise noted, Ta = 25°C, Vcc = 10V, fin = 1kHz, VIN = 150mV, RL = 100kΩ)

| Parameter | Symbol | Min. | Typ. | Max. | Unit | Conditions |
|----------------------------------|--------|------|------|------|-------|---|
| Quiescent current | Iq | 1.6 | 2.4 | 3.3 | mA | Through mode |
| Maximum output voltage | Vom | 2.3 | 2.8 | — | Vrms | THD = 1%, through mode |
| L / R gain | GVT | 10 | 14 | 17 | dB | Through mode |
| Low frequency gain | GvF | 10 | 14 | 17 | dB | fin = 50kHz, vocal fader mode |
| Microphone gain | GvM | 5 | 8 | 11 | dB | — |
| Crosstalk | CT | 54 | 70 | — | dB | fin = 1kHz |
| Mute attenuation | MU | 73 | 80 | — | dB | fin = 1kHz |
| Vocal suppression rate | SV | 28 | 33 | — | dB | Vocal fader mode |
| Total harmonic distortion | THD | — | 0.02 | 0.07 | % | Through mode, BW : 400Hz - 30kHz |
| Noise level | VN | — | 15 | 22 | μVrms | Rg = 0, DIN AUDIO |
| Input impedance | RIN | 35 | 50 | 65 | kΩ | LIN, RIN, MICIN, FK |
| Control pin threshold (high) | VthH | 4.7 | — | — | V | — |
| Control pin threshold (low) | VthL | — | — | 0.3 | V | — |
| Output switching DC differential | ΔDC | — | 7 | 26 | mV | Maximum output voltage differential between L, R and TK modes |

○ Not designed for radiation resistance.

Mode table (A = pin14, B = pin15, C = pin16)

| A B C | LOUT | ROUT | TK | Mode | Key controller mode |
|-------|------|------|-------|-------------------------|---------------------|
| 0 0 0 | MUTE | MUTE | MUTE | Mute | — |
| 0 0 1 | VF | VF | VF | Vocal fader mode | — |
| 0 1 0 | L | L | L | Sound multiplexing mode | — |
| 0 1 1 | L | R | L | Through mode | — |
| 1 0 0 | MUTE | MUTE | MUTE | Mute | ● |
| 1 0 1 | KC | KC | VF | Vocal fader mode | ● |
| 1 1 0 | KC | KC | L | Sound multiplexing mode | ● |
| 1 1 1 | KC | KC | L + R | L + R | ● |

0 : 0V 1 : 5V

VF : vocal fader output

KC : signal passed through key controller

(1) Microphone output is not muted during muting (ABC = 000 or 100).

(2) Gain and relative phase: See block diagram.

1. L / R input and output in the through mode are synchronous with a gain of 14dB.
2. L / R input and TK output in the key controller mode are synchronous with a gain of 8dB.
3. FK input and L / R output in the key controller mode are synchronous with a gain of 6dB.
4. MIC input and L / R output are negative phase with a gain of 8dB.

BA3838F (unless otherwise noted, Ta = 25°C, Vcc = 10V, fin = 1kHz, VIN = 150mV, Ri = 100Ω)

| Parameter | Symbol | Min. | Typ. | Max. | Unit | Conditions |
|----------------------------------|------------------|------|------|------|-------|---|
| Quiescent current | I _Q | 1.9 | 2.7 | 3.6 | mA | Through mode |
| Maximum output voltage | V _{om} | 2.3 | 2.8 | — | Vrms | THD = 1%, through mode |
| L / R gain | G _{VT} | 10 | 14 | 17 | dB | Through mode |
| Low frequency gain | G _{VF} | 10 | 14 | 17 | dB | fin = 50kHz, vocal fader mode |
| Microphone gain | G _{VM} | 5 | 8 | 11 | dB | — |
| Crosstalk | CT | 54 | 70 | — | dB | fin = 1kHz |
| Vocal suppression rate | SV | 28 | 33 | — | dB | Vocal fader mode |
| Total harmonic distortion | THD | — | 0.02 | 0.07 | % | Through mode, BW : 400Hz - 30kHz |
| Noise level | V _N | — | 15 | 22 | μVrms | R _g = 0, DIN AUDIO, through mode |
| Input impedance | R _{IN} | 35 | 50 | 65 | kΩ | LIN, RIN, MICIN, FK |
| Control pin threshold (high) | V _{thH} | 4.7 | — | — | V | — |
| Control pin threshold (low) | V _{thL} | — | — | 0.3 | V | — |
| Output switching DC differential | ΔDC | — | 7 | 46 | mV | Maximum output voltage differential between L, R and TK modes |

○ Not designed for radiation resistance.

Mode table (A = pin14, B = pin15, C = pin16)

| A | B | C | LOUT | ROUT | TK | Mode | Key controller mode |
|---|---|---|------|------|-------|--------------------------------|---------------------|
| 0 | 0 | 0 | R | R | R | Sound multiplexing mode (ROUT) | — |
| 0 | 0 | 1 | VF | VF | VF | Vocal fader mode | — |
| 0 | 1 | 0 | L | L | L | Sound multiplexing (LOUT) | — |
| 0 | 1 | 1 | L | R | L | Through mode | — |
| 1 | 0 | 0 | KC | KC | R | Sound multiplexing (R) | ● |
| 1 | 0 | 1 | KC | KC | VF | Vocal fader mode | ● |
| 1 | 1 | 0 | KC | KC | L | Sound multiplexing mode (L) | ● |
| 1 | 1 | 1 | KC | KC | L + R | L + R | ● |

0 : 0V 1 : 5V

VF : vocal fader output

KC : signal passed through key controller

* Gain and relative phase: See block diagram.

- Gain of L / R input and output in the through mode: 14 dB (synchronous)
- Gain of L / R input and TK output in the key controller mode: 8dB (synchronous)
- Gain of FK input and L / R output in the key controller mode: 6dB (synchronous)
- MIC input and L / R output are negative phase with a gain of 8dB.

● Measurement circuit (BA3838F)

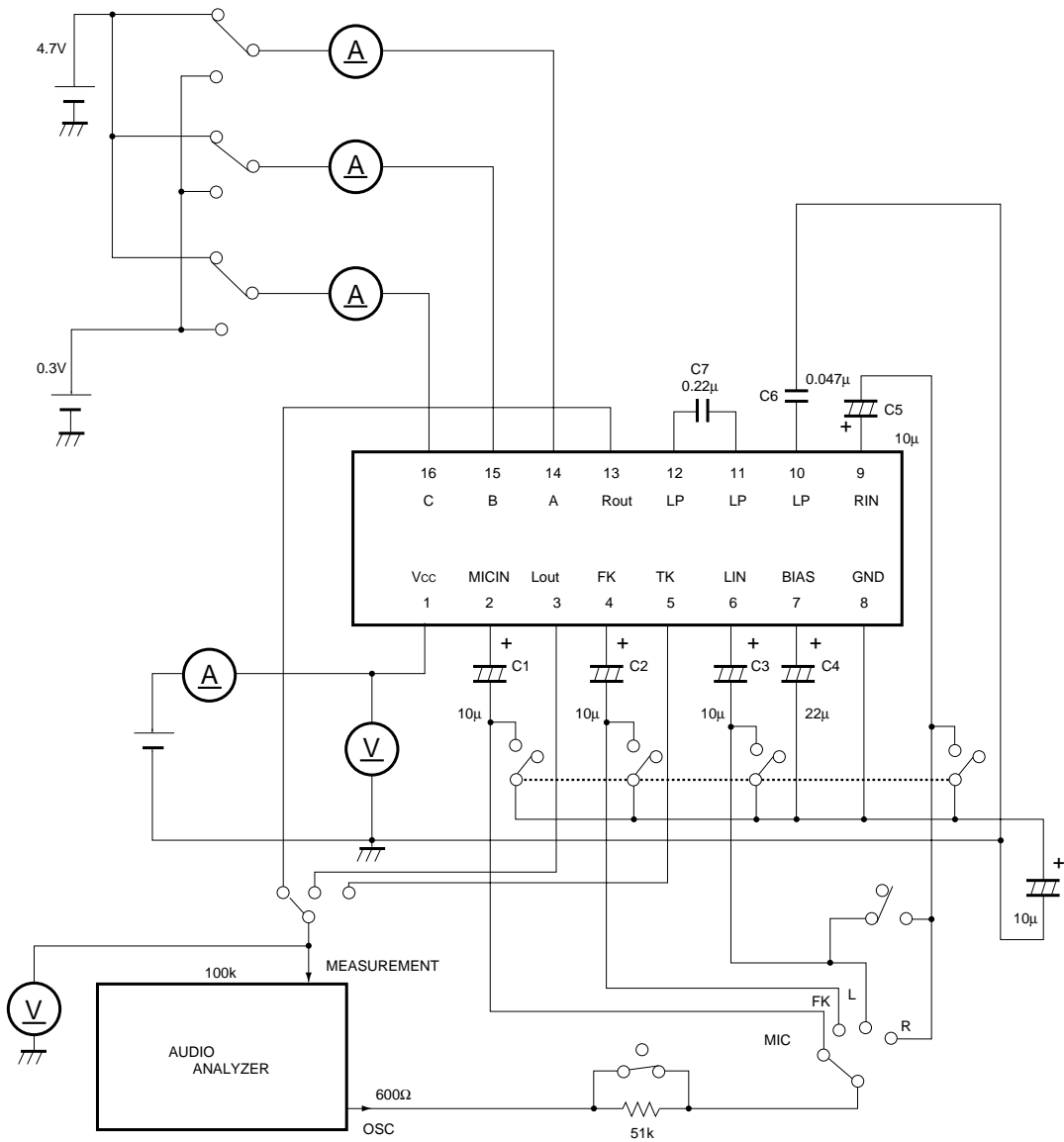

Fig. 1

●Application example (BA3838F)

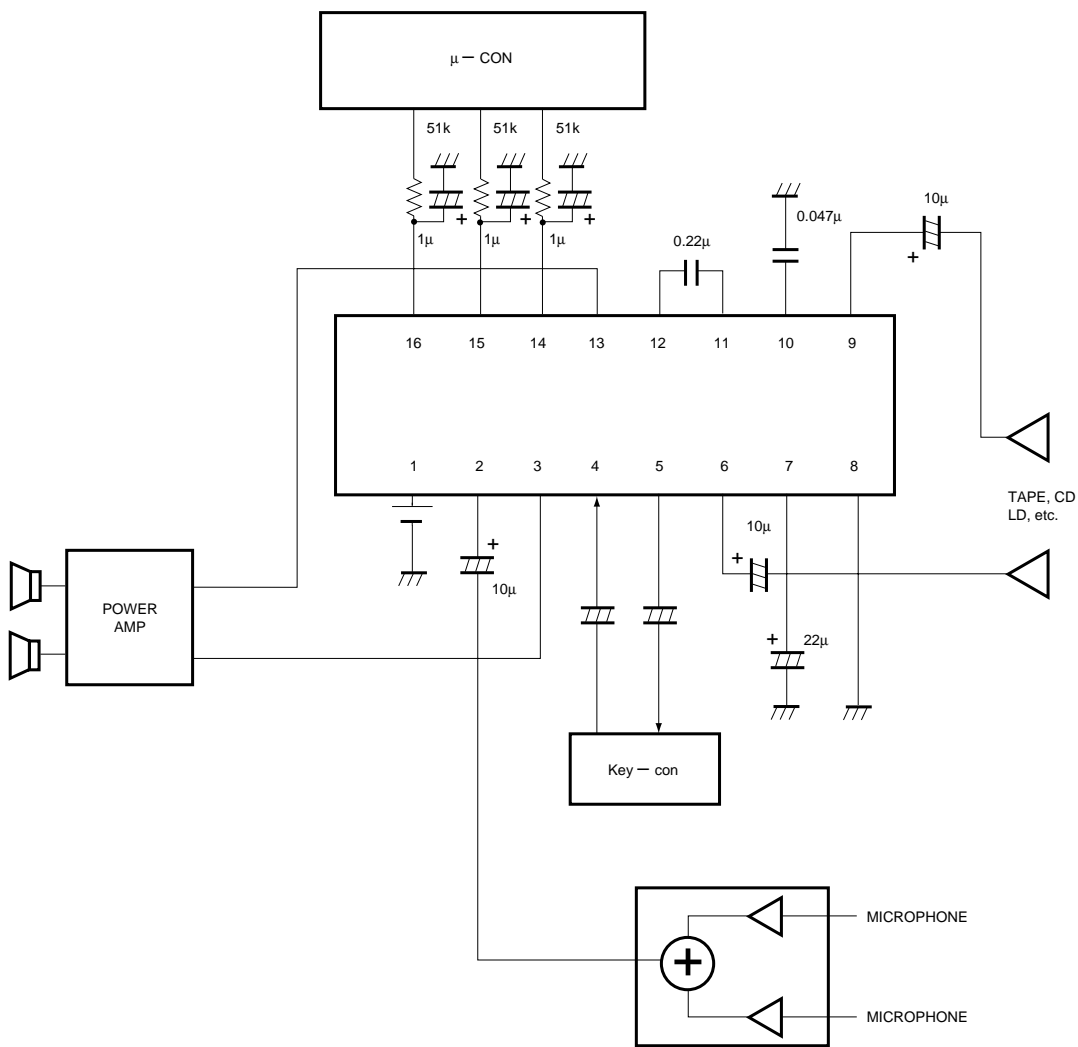

Fig. 2

●Operation notes

- (1) The example in the diagram “Application example” is recommended with confidence. However, be sure to comply with these precautions and verify characteristics during actual use. Also, when changing an attached circuit constant, be sure to allow sufficient margins by taking into account both static and transient characteristics, including variation in these ICs and the attached components.
- (2) The low pass filter cutoff frequency is determined by the internal circuitry and by C_6 and C_7 in Fig. 1. With the constant used in Fig. 1, the cutoff frequency (f_c) is roughly 150Hz. This cutoff frequency can be changed by changing C_6 and C_7 . When C_6 is multiple a, and C_7 is multiple b, respectively, the cutoff frequency is calculated thus:

$$f_c = \frac{150}{\sqrt{ab}} \text{ (Hz)}$$
 The value of Q is: $Q = \frac{1}{2} \sqrt{\frac{C_7}{C_6}}$
 (Currently, $Q \cong 1$)
- (3) For the gain and relative phase of the input pin (LIN, RIN, MICIN and FK) inputs and output pin (LOUT, ROUT and TK) outputs, refer to “Gain and relative phase,” on page 2 / 10.
- (4) Electrical characteristics are measured at a load resistance (R_L) of roughly 100k Ω . As using an extremely low load resistance (below 10k Ω) will result in slight variation in maximum output voltage and total harmonic distortion, caution must be used when designing connections with the subsequent stage.
- (5) The pin 7 bias voltage is roughly $V_{cc} / 2$. Because this is also the input and output pin voltage, select coupling capacitor polarity according to relative potential and the characteristics of the components to which the coupling capacitor is to be connected.
- (6) When outputting L + R from LOUT and ROUT in an application in which the key controller is left unconnected, attach a 10 μ F electrolytic capacitor between pins 4 and 5, with pin 5 being positive (L + R mode: ABC = 111).
- (7) Connecting a capacitance load to pin 5 (TK) of BA3837 / F can worsen noise characteristics. When connecting a capacitance load higher than 10 μ F, insert 1k Ω in series (Figs. 1 and 2). The pin 5 output impedance is roughly 5 Ω (1kHz). In the BA3838F it is roughly 400 Ω (1kHz).
- (8) The vocal fader works by canceling out the synchronous component of the signal, leaving the low components in place. Consequently, the vocal fader may not be very effective with certain recordings.
- (9) In cases where output DC differential can cause noise when switching between modes, use a time constant for the timing of control pin switching, or take some other measure.
- (10) Operating supply voltage may vary according to ambient temperature. Using this IC outside the recommended supply voltage range may result in increased crosstalk or mute attenuation.

●Electrical characteristic curves

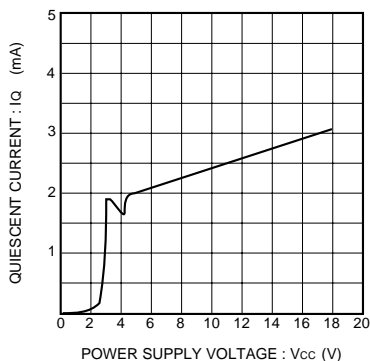

Fig. 3 I_q vs. V_{cc} characteristics (BA3837 / F)

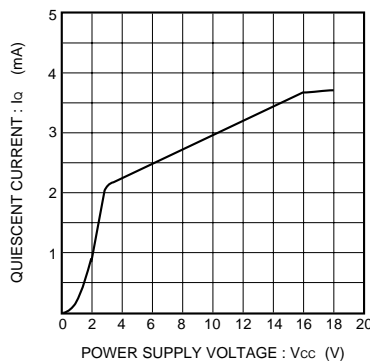

Fig. 4 I_q vs. V_{cc} characteristics (BA3838F)

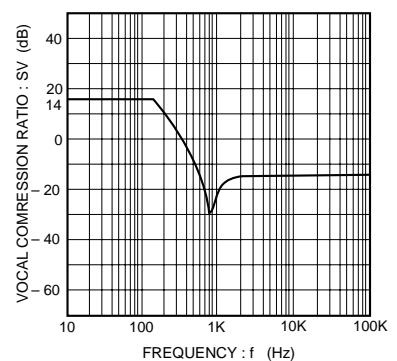

Fig. 5 SV vs. frequency characteristics

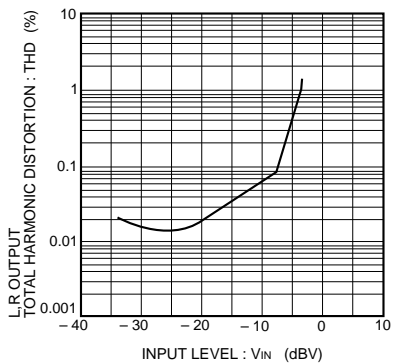

Fig. 6 THD vs. V_{IN} characteristics

●External dimensions (Units: mm)

